

Data Protection for Fujitsu Integrated System PRIMEFLEX with Veeam Software

White Paper

Veeam entered the market as a backup & restore solution radically optimized for VMware environments. Learn how Veeam has developed their software to support converged, hyper-converged, and hybrid cloud infrastructure solutions from Fujitsu.

Content

1	Introduction	2
2	What you need to know about today and tomorrow.....	2
3	Veeam as the innovator of data protection software and new usage scenarios.....	3
4	What makes Veeam a perfect fit for converged infrastructure solutions?	4
5	What makes Veeam a perfect fit for hyper-converged infrastructure solutions?	8
6	Perfect combination: Nutanix Mine with Veeam on Fujitsu XF systems	9
7	What makes Veeam a perfect fit for SAP solutions?.....	9
8	What different appliances are available for PRIMEFLEX environments?	9
9	Reflection on opening statements and summary.....	11
10	Link Collection with further information.....	12



1 Introduction

We at Fujitsu partner with the major software vendors for backup, restore and archiving. It is important to us not only to be able to consult you in designing the right virtualized or software-defined infrastructure, but also to combine it with the individually best-fitting data protection environment. Consolidating primary, secondary and tertiary data assets under one roof is helping to harmonize service and support – resulting in less trouble, less cost and better operations. To facilitate this task, we enable our customers to become acquainted with the different value propositions and technical scopes of Veritas, Commvault and Veeam.

The Veeam Data Protection white paper for technical decision makers and influencers has the following structure:

- A brief introduction into the world of data protection - today and tomorrow
- Veeam as the innovator of data protection software and new usage scenarios
- What makes Veeam a perfect fit for converged infrastructure solutions?
- What makes Veeam a perfect fit for hyper-converged infrastructure solutions?
- What different data protection appliances are available?
- Reflection on opening statements and summary

2 What you need to know about today and tomorrow

Historically, we saw each production platform (mainframe, midrange, NetWare, Windows, virtual) usurp the one before it – but that is not true this time. This time it is about adding. For most organizations that are investigating cloud services (plural), there isn't as clear a sentiment that they are "turning off" their existing datacenters, as much as extending them within a multi-cloud strategy. Consequently, it is critical that, as workloads evolve from on-premises platforms (e.g., Exchange) to cloud services (e.g., Office 365), you should not devolve from "well-protected" to "non-protected." To understand what that means, we must categorize the complexity that your organization will be challenged with today and tomorrow. In the past you were backing up servers, then VMs, now maybe containers, while in the cloud era your job is to recover complete cloud native apps and database environments, or simply put services.

Moving from servers to services does not absolve you of the long-term retention and multi-version operational recovery mandates that IT has always been governed by, but it can complicate your strategy if you are not mindful of the different mechanisms and processes necessary to protect these newer platforms. To ignore that reality is to put your data, and your organization, in peril. Said another way, if data centers were still running standalone SQL and Exchange on top of older Windows Server, no one would spend any money on backup, other than adding backup capacity. However, as workloads change, legacy backup mechanisms and strategies become woefully inadequate. So, when you modernize production, you must modernize protection.

3 Veeam as the innovator of data protection software and new usage scenarios

Why Veeam can play the center role in your IT innovation strategy

The reason why so many in IT categorize backup as a “dead” investment is because they perceive the collected data as unusable, “dead”. Up to that moment (which hopefully never comes) when something has been deleted or was even destroyed so that the “dead” data needs to be revived again. Then the “dead” investment is producing some RoI (return on invest) and the whole investment then becomes justified. Veeam’s strategic credo is to enable customers to use their backup data in a productive way in every form imaginable. Veeam has a built-in, cost-free sandbox environment, which they call “DataLabs”. This highly developed sandbox system enables the data protection IT staff to differentiate between “productive” (hot/active = don't-touch) data and “Backup” (copied/cold = you're-ok-to-experiment-with-this) data. Providing their colleagues from the different departments with data resources, they can instantaneously use these to analyze, simulate, bend, transform and extrapolate. Here are some real-life examples:

- IT operations can now do preemptive patching, backup restore validation, Dev/Test, Business Continuity/DR
- Finance / Analytics
- HR / Legal for compliance and training purposes

Not stealing away any of the primary storage resources, not suppressing any latencies, not having the risk of corrupting, or even deleting actual data or the data they rely on, the backups itself.

Veeam is the inventor of agentless backups

Coming back to the “normal” everyday task of protecting data assets: It is still remarkable how proud Veeam technicians emphasize that this epochal innovation was able to reshape the market landscape for data protection software. The classic approach to install backup agents in every server-instance was maybe practical in the pre-era of virtualization but was representing a major burden for data protection admins in the time of VM sprawl. Veeam made it clear that another approach needed to come to life: the agentless-backup for virtual machines. Veeam’s consequent aim was and is to enable the backup admin to manage every task through the main GUI of Veeam Backup & Replication™. The IT administrator does not have go to a certain VM and install a plug-in into a database or application stack. The only environments where backup agents still need to be installed are Oracle RMAN and SAP backint – either way, running physical or virtualized. Imagine, what this epochal innovation would mean for rolling out and maintaining your complete backup environment.

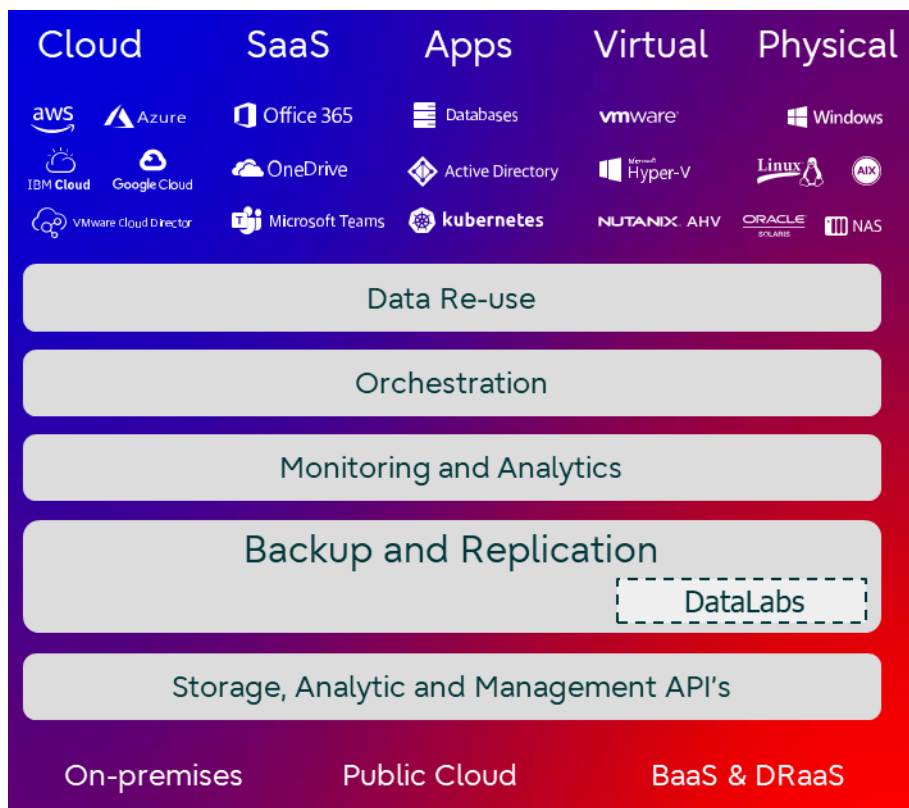

Figure 1: Veeam Cloud Data Management Platform

Veeam is pushing the envelope for maximum flexibility

Investing into a Fujitsu Integrated System PRIMEFLEX gives you the peace of mind to be able to consolidate all your VMs and containers on a single CI/HCI platform. The vertical, software-defined software stacks of Nutanix, VMware and Microsoft offer the support for virtualized Windows and Linux instances and enable mobility of these VMs/Containers (and their connected data) into the cloud. What Veeam is enabling you to do, as an example, is to back up a cloud-run VMware ESXi based VM and recover it on-premises on a PRIMEFLEX for Microsoft Azure Stack HCI cluster – running solely on Hyper-V. This cross-platform restore capability sets a new bar for flexibility in daily backup operations.

4 What makes Veeam a perfect fit for converged infrastructure solutions?

PRIMEFLEX for VMware vSphere provides a fast track to production

The converged solution is a fully pre-configured, pre-tested and validated package of best-in-class hardware, software, integration and support services from Fujitsu. It is designed to provide a fast track to maximum IT performance and agility while also reducing complexity for VMware-based virtual infrastructures. The solution gives businesses full flexibility to scale compute and storage performance independently according to changing requirements, all within a self-contained, ready-to-run solution. Inside, Fujitsu PRIMEFLEX for VMware vSphere combines the latest [Fujitsu PRIMERGY RX dual-socket servers](#) with a choice of either [Fujitsu ETERNUS AF all-flash or ETERNUS DX hybrid storage](#).

How is the integration of Veeam Software with Fujitsu ETERNUS data protection solutions?

With the availability of the Veeam storage snapshot plug-in for Fujitsu ETERNUS AF all-flash and ETERNUS DX hybrid storage, customers can create complete VM backups and replicas from snapshots as often as they like, with little to no impact on their production environment. This advanced data protection capability bridges the gap between critical recovery point objective (RPO) and recovery time objective (RTO) storage targets. Fujitsu ETERNUS storage can also be used as a high-speed target for backup of virtual machines, not to mention the backup capabilities into physical tape and cloud environments.

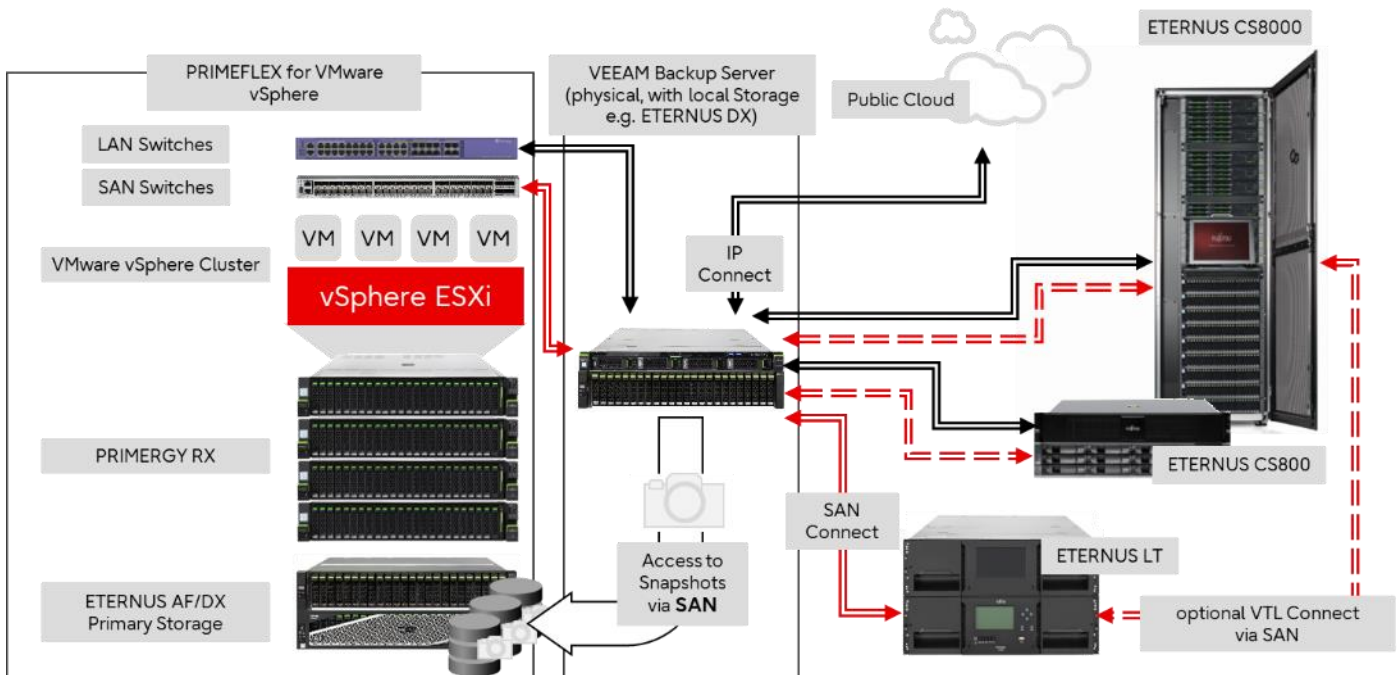

Figure 2: Integration of Veeam Software

Veeam has strong cloud competencies

Based on the hybrid capabilities you have now gained with implementing a PRIMEFLEX Integrated System, it would be a shame not to mention the attractive possibility to integrate public cloud offerings into your data protection strategy. This can be disaster recovery, cold storage requirements or S3 object storage targets.

This common ecosystem enables data protection to begin in primary storage, which offers several advantages, especially for virtual environments.

Accelerate Backup and Recovery with snapshots

- Veeam supports hardware snapshots of Fujitsu storage arrays

Veeam Backup & Replication™ combined with Fujitsu ETERNUS storage hardware is a simplified data availability solution that satisfies modern service levels of relevance to the recovery of IT services, including data and applications.

A very important feature is how fast storage integrations can be added with the **Veeam Universal Storage API**. This framework was introduced with Veeam Backup & Replication 9.5 Update 3 and has allowed Veeam and its alliance partners to rapidly add new supported storage systems. This Veeam Plug-In supports Fujitsu Storage ETERNUS AF, DX and ETERNUS Storage Cluster configurations providing many outstanding capabilities:

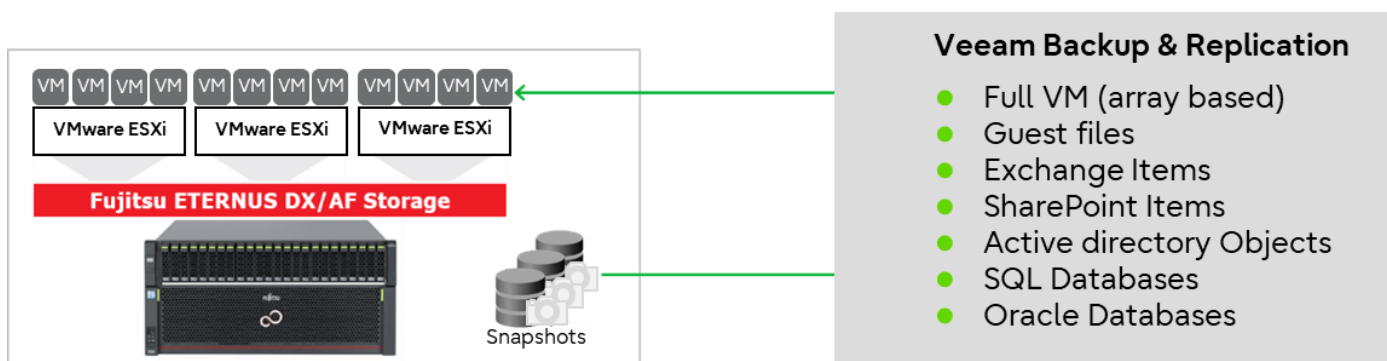

Figure 3: Snapshot integration

Backup from storage snapshots lets you speed up backup and replication for VMware vSphere VMs whose disks are hosted on storage systems. It allows the data mover (a Veeam VMware Backup Proxy) to do the heavy lifting of a backup job from the storage snapshot rather than from a conventional VMware vSphere snapshot. This integration will allow organizations to take backups or replicas at any time of the day, maintaining VMware Changed Block Tracking (CBT) and application consistency. It also reduces impact of backup and replication activities on the production environment and improves RPOs.

- Veeam explorer for fast recovery

Veeam Explorer for Storage Snapshots is a technology in Veeam Backup & Replication that allows you to restore VMware VM data directly from native storage snapshots. It automates the process of data recovery for VMs hosted on storage systems and eliminates intermediate restore and manual operations. As a result, it is possible to restore necessary VM data from storage snapshots in seconds. There are multiple Veeam Explorer options available: For Microsoft Active Directory, Exchange, SQL, Oracle and File.

- On-demand sandbox feature for testing

As part of Veeam DataLabs, there is the option to start VMs from existing snapshots on the production storage array. You can use the on-demand sandbox to test VMs, troubleshoot issues, perform training, etc. This turns out to be a huge help to organizations by avoiding changes that do not go as expected. You will be able to answer questions like “How long will it take?”, “What will happen?”, and, most importantly, “Will it work?”.

- Veeam orchestrates primary storage snapshots

The Veeam plug-in for Fujitsu ETERNUS DX/AF storage will also allow you to instruct Veeam to constantly create new snapshots (and automatically/manually delete them after a while). These jobs will not produce a backup but will produce a storage snapshot that can be used with shorter RPO's than a classic backup and with the Veeam Explorer for Storage Snapshots you'll be able to recover even faster than from a backup.

- Veeam Snapshot Plug-In supports storage cluster configurations

The Veeam snapshot plugin is also aware of ETERNUS Storage Cluster environments. When it comes to mission-critical data that must be available around the clock, a disaster-proof configuration is an absolute must.

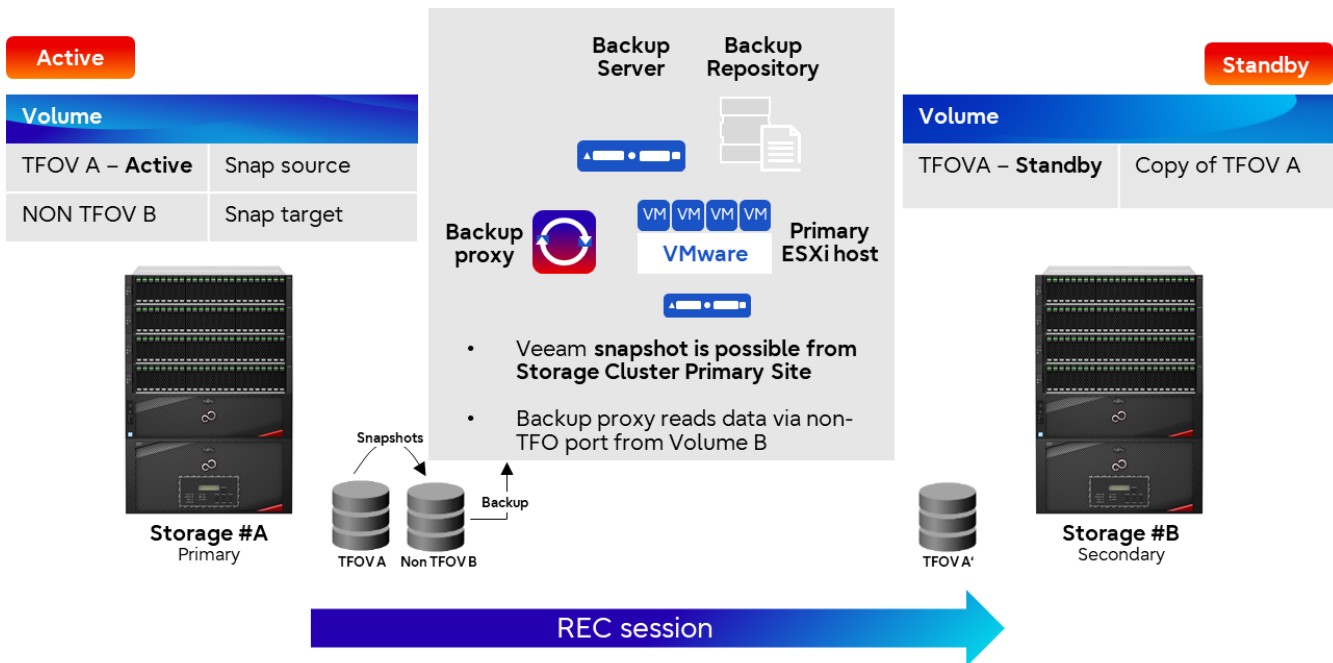

Figure 4: Storage Cluster in normal operation

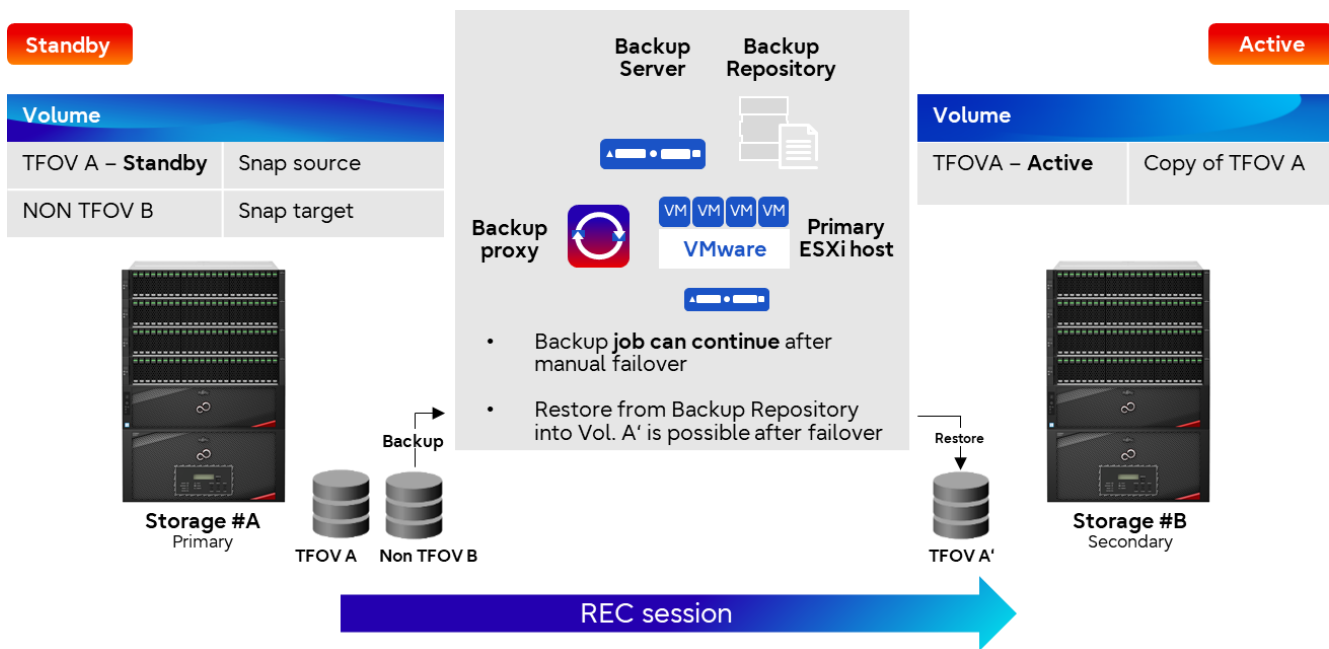

Figure 5: Storage Cluster after manual failover

Fujitsu VBR Plugin is able to trigger a snapshot of the active Transparent Failover Volumes (TFOV) available at the primary site of the cluster. After failover has processed, the backup existing in backup repository can be restored to the corresponding TFOVs on the secondary site.

Non-stop operations with transparent failover in ETERNUS Storage Cluster configurations can be executed in both directions, either automatically or manually. A manual failover process is required in the event of planned power shutdowns, DR tests and non-disruptive upgrades.

For more details refer to the following white paper: [ETERNUS AF/DX Storage Cluster](#)

5 What makes Veeam a perfect fit for hyper-converged infrastructure solutions?

What is a typical hyper-converged scenario?

In reference to the diagram stated above showing the best practices for implementing a Veeam data protection environment for a converged infrastructure, the picture changes substantially for hyper-converged scenarios.

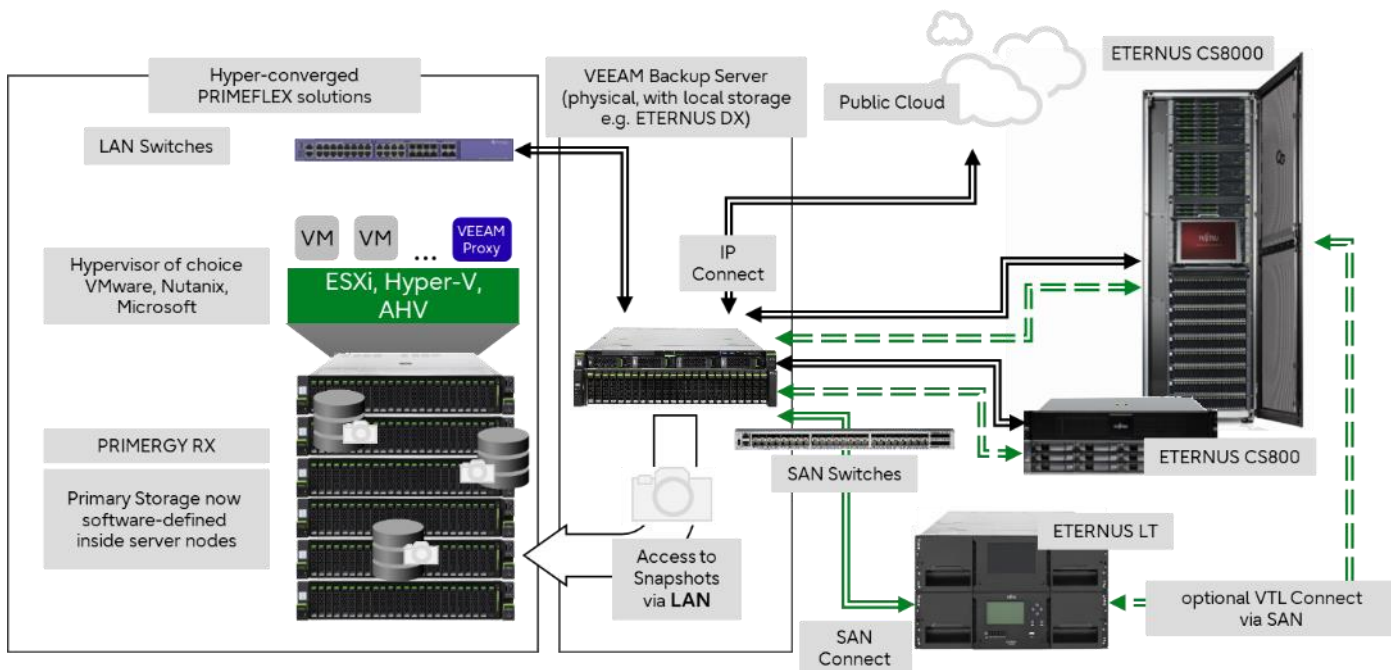

Figure 6: Typical hyper-converged scenario

Here, all data transfer from the HCI servers to the Veeam backup server(s) is IP based, while customers still have the flexibility to choose different network technologies to transport the backup data to the different target repositories. Fairly often, customers organize their long-term retention storage in a separate recovery site in a disaster-safe place somewhere else on their campus. For connecting this recovery site with the primary storage site, fiber channel SAN technology is normally the best choice to bridge the longer distances. If all storage is kept in one place, SAS connectivity to the tape device is seen more often.

PRIMEFLEX for VMware vSAN maximizes operational experience

Veeam recognizes which server node runs which VM and data store and can then automatically direct the data stream to the target appliance. By having a Veeam Proxy VM on each physical node of the cluster, it is possible to parallelize the backup streaming.

PRIMEFLEX for Microsoft Azure Stack HCI unlocks the power of hybrid IT

For Azure Stack HCI, Veeam installs a data mover on each cluster node, which takes on a “proxy role” inside the Hyper-V hypervisor. The integration in the “Dom 0” is a perfect example of how deep the integration with Microsoft really has become.

PRIMEFLEX for Nutanix Enterprise Cloud simplifies the deployment across edge-core-cloud

To activate parallel streaming, our customers using VMware ESXi on Nutanix have to install one of the Veeam Proxy VMs on each physical node of the vSphere Cluster. The case changes if the customer runs the Nutanix Acropolis Hypervisor (AHV) based cluster. In this case, the Veeam Proxy VM is installed as a single instance in the AHV cluster.

6 Perfect combination: Nutanix Mine with Veeam on Fujitsu XF systems

Nutanix Mine deployed as a Nutanix data protection appliance

In addition to the integration of the Veeam console into Nutanix PRISM / PRISM Pro management GUI, Veeam and Nutanix have developed a data protection



solution that can use the AHV cluster technology as a target appliance. This joint appliance is called Nutanix Mine. The beauty of this lies in the high levels of backup automation: PRISM/PRISM Pro will “understand” when new workloads (and accompanying data assets) are being generated on the primary AHV cluster and will automatically include these into the existing backup process.

Configurations of Nutanix Mine available on Nutanix-certified XF systems

As part of Fujitsu PRIMEFLEX, Nutanix Mine is available on Nutanix-certified XF systems (Fujitsu Integrated System PRIMEFLEX for Nutanix Enterprise Cloud), starting with a minimum of four nodes. Fujitsu supports several configurations for running Mine with Veeam depending on your needs. As a comprehensive data protection and management solution that includes all the hardware and software components required to support any virtualized or legacy environment, Nutanix Mine with Veeam enables granular data backup and recovery for all applications. It brings the simplicity and scale of Nutanix Cloud Platform and Veeam's enterprise backup and cloud data management capabilities to address customers' backup, long-term retention, and archiving needs.

7 What makes Veeam a perfect fit for SAP solutions?

Optimize your SAP infrastructure with PRIMEFLEX for SAP HANA

Veeam® provides an SAP-certified backup and recovery solution, Veeam Plug-in for SAP HANA, which allows enterprise customers to seamlessly integrate native SAP HANA Backint backups with the industry-leading Veeam Backup & Replication™ solution. Organizations can optimally back up their mission-critical, performance-sensitive SAP HANA environments so they can better address the high demands on the availability of applications and data. With the Veeam Plug-in for SAP HANA you can easily:

- Protect SAP HANA natively with SAP HANA tools including Studio, Cockpit and SQL commands
- Process backup logs according to your log backup interval with Backint integration
- Perform recovery using native SAP HANA tools that require no special training for DBAs

Discover detailed information on [Veeam.com: Solution Brief: Veeam Plug-in for SAP HANA](#) / [White paper: Veeam SAP HANA Availability Guide](#)

8 What different appliances are available for PRIMEFLEX environments?

Fujitsu Storage ETERNUS CS800 is a target appliance for backup

The ETERNUS CS800 is a turnkey, easy to operate backup-to-disk appliance supporting all market-relevant backup suites providing the following benefits:

- Leading deduplication technology reduces disk capacity by up to 95%, saving tremendous storage and environmental cost.
- Veeam Data Mover Service (VDMS) is already pre-installed and can be activated by purchasing the accompanying license key and reduces infrastructure cost.
- Disaster recovery capabilities through optimized replication (NAS and VTL) protect your business-critical data ensuring business continuity.

The ETERNUS CS800 fits best for:

- Backup of PRIMEFLEX environments for branch offices, for small, medium and upper medium customers
- Daily backups starting small and ranging up to 50 TB per day (depending on use case)

Long-term data protection with Veeam Data Mover Service (VDMS)

3-2-1 Rule

- 3 Copies of data
- 2 Different storage types
- 1 Remote location

Above all, the snapshot integration mentioned above provides an efficient and fast backup and recovery option. The temporary storage of data on the Veeam backup or proxy server based on Fujitsu PRIMERGY servers with very fast block storage (e.g., ETERNUS DX) or network shares (ETERNUS CS) allows the special needs of recovery requirements or data volumes to be met. In this combination, the Veeam recovery options can be used. In addition, the data protection appliances ETERNUS CS800 and ETERNUS CS8000 provide powerful infrastructure solutions for Veeam secondary backup copies.

Depending on the model the ETERNUS CS800 supports VDMS, which is installed ready-to-use. This integration enables a direct connection to the Veeam Server/Proxy without a gateway, which actively supports Veeam data storage. In addition, the ecosystem can be complemented by ETERNUS LT tape solutions, which can be used to optimally implement the 3-2-1 backup and more. Store at least three copies of the data, store two backup copies on different storage media, store one backup copy at a remote location or offline through the simple and efficient operation of a tape library (e.g., ETERNUS LT).

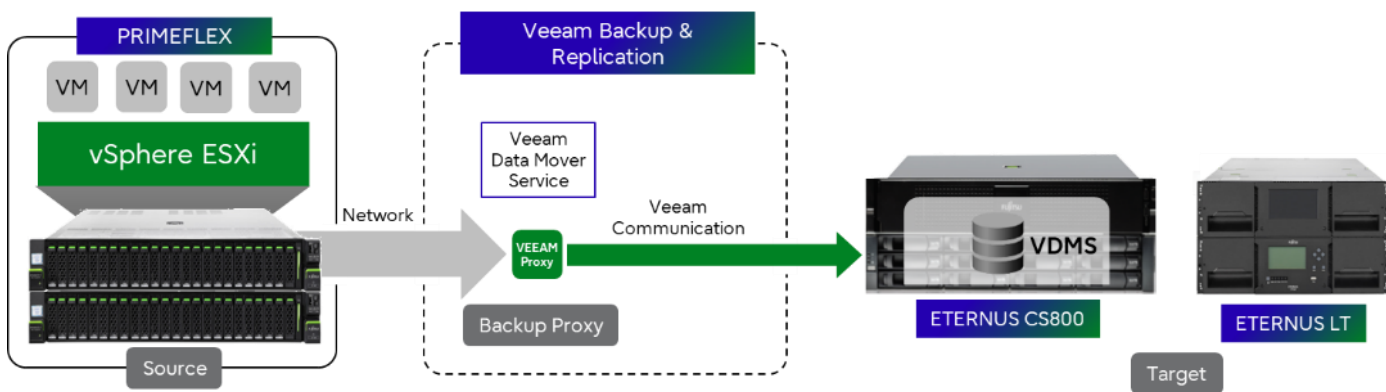

Figure 7: Veeam Data Mover Service with Fujitsu Storage ETERNUS

Although Veeam Backup & Replication feature deduplication/compression, these are off-loaded to the original ETERNUS CS800 software capabilities. Veeam also features software-based encryption, which in this scenario does not make sense. If encryption is required though, ETERNUS CS800 customers can select a portfolio of self-encrypting drives (SED) to make full use of hardware-based encryption performance.

Fujitsu Storage ETERNUS CS8000 is a target appliance for backup and archiving

The ETERNUS CS8000 is a reliable data center solution for enterprise backup and archiving for mainframe and open systems providing a central repository for backup, archive, second tier and object data.

- The ETERNUS CS8000 software CentricStor offers intelligent automation features, relieving admins from workload, and ensuring higher and more reliable service levels.
- Advanced VTL features (e.g., dual- or triple safe, cache mirror, etc.) that can be combined with the capabilities of the Veeam software can lead to huge TCO reductions in complex backup environments.
- WORM functionality enables compliant archiving.
- No other data protection appliance in the market allows customers to design a synchronous replication architecture between two data centers.
- One of the highly appreciated features of the software is a function called "Tape refresh", which automatically handles necessary transitions from older to newer tape media and robotic technology.

The ETERNUS CS8000 is ideally suited for:

- Upper medium and large enterprises to protect data from edge-core-cloud.
- Service providers due to flexible “Scale” and “Growth” on-demand purchasing options.
- Daily backup larger than 50 TB.
- Customers with challenging backup and archiving SLAs like the need to support multiple media types or design an architecture with no single point of failure.
- Data-driven organization to support large amounts of data ranging up to 60 Petabytes disk cache plus virtually unlimited capacities on tape media.
- Thwarting ransomware with an 3-2-1 approach combining backup and archive to disk and tape.
- For heterogeneous environment with open systems and mainframes. ETERNUS CS8000 uses one software GUI for handling the backup data of mainframe and open system (e.g., x86, VMs, Unix, etc.).

For more details about our data protection portfolio please refer to the [webpage](#).

9 Reflection on opening statements and summary

Data protection challenges for data-driven organizations

Referring to the beginning of the “new requirements” around Hybrid IT and the challenges derived from that for backup & archive, we can only give the good advice to alter the importance of a consistent data protection strategy. In Fujitsu’s perspective, data protection responsible managers and administrators should embrace a “pro-active” stance to question their colleagues who are responsible for data creation and processing (and security) about their innovation plans for the company’s IT landscape.

To even accelerate these initiatives, “challenge” the business leaders with questions like these:

- “How long can your operations function if the IT systems go offline?”
- “If the IT systems go offline, how long does it really take to get them running again?”
- Then ask your peers in IT a follow-up question: “When was the last time that we tested and confirmed that?”

While tactical IT initiatives may be obvious, strategic IT initiatives are often hindered by a lack of practical visibility and understanding of what is working and what is not. If you can only “see or do” the tactical functions, without understanding how the pieces relate to each other, you won’t go very far. The same abstractions in cloud and virtual environments that accelerate production initiatives create challenges for data protection/data management, BC/DR, and similar initiatives such as cybersecurity. One best practice is to formulate backup & archive SLAs – following a consensus-based understanding about important, “most-” & “utmost-” important categories of data for your business.

10 Link Collection with further information

Internet:

- www.veeam.com
- www.fujitsu.com/veeam
- www.fujitsu.com/primeflex

White paper: [Data Protection for the Digital World](#)

Contact us

to find out how we can help you to protect your data in your hybrid environment
to ensure 24/7 business continuity.

Contact

Fujitsu Technology Solutions GmbH

Mies-van-der-Rohe-Strasse 8

D-80807 Munich

Internet: www.fujitsu.com/dataprotection

Date: 2022-09-30 ww-en

© Fujitsu 2022. All rights reserved. Fujitsu and Fujitsu logo are trademarks of Fujitsu Limited registered in many jurisdictions worldwide. Other product, service and company names mentioned herein may be trademarks of Fujitsu or other companies. This document is current as of the initial date of publication and subject to be changed by Fujitsu without notice. This material is provided for information purposes only and Fujitsu assumes no liability related to its use. FUJITSU-PUBLIC